

## Features:

- ▲ Large Touch Screen or Two Line + Button Models
- ▲ Single Firmware Board with TCP/IP communication
- ▲ Online and offline mode
- ▲ Thermal bar-coded tickets (3.5" by 2.3")
- ▲ Custom ticket logos and non transient access cards
- ▲ Units are shipped with barcode scanner and configured for plug-n-play HID and AVI(optional)
- ▲ System uses inexpensive barcode access cards that allow monthly and frequent parker entry/exit
- ▲ Remote updates, remote management, remote trouble shooting
- ▲ Few moving parts (low maintenance cost)

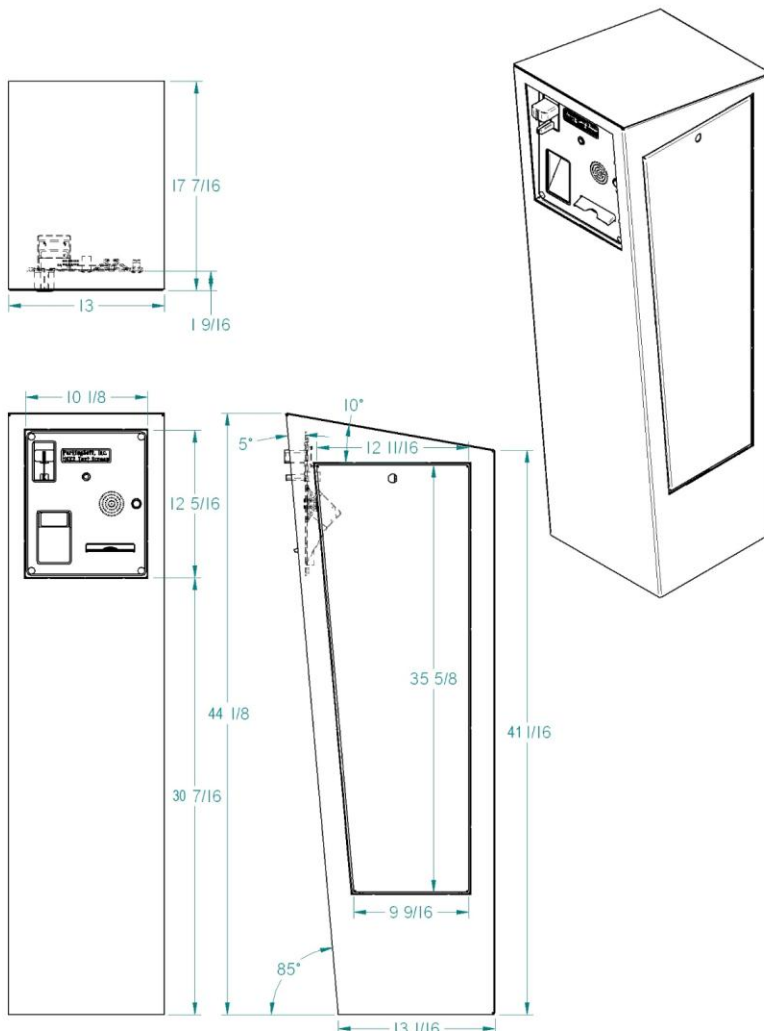

## Specifications:

### Electrical

120V AC, 60 Hz  
 5 amp max. at 120V  
 I/O for gate vend, lane counts, reversible lanes

### Mechanical

Thermal printer  
 Omni-directional barcode scanner  
 Color TFT display with vandal-resistant touch screen

### Housing

12 gauge (2.8mm) steel  
 44"H x 13"W X 13" D  
 Weight: 90 pounds  
 Color: Gibraltar Gray, Pure White(RAL #9010) and custom

### Environment

Temperature: -20F to 122 F  
 Humidity: 10% - 95% (non-condensing)

### Printer

Resolution: 203 dpi(8 dots/mm)  
 Print width: 2.1" (54 mm)  
 Print speed: 5.9" (150 mm) per sec

### Paper

Thickness: 7.60 ~ 0.60 mils /193 ~ um  
 Width: 2.3" (58 mm)  
 Roll: 6" - 10"

### Options

HID/AVI reader  
 Width: 2.3" (58 mm)  
 6" or 2" base

